

V2X R&D PROGRESS IN CHANGAN

Li Zengwen
Director, Advanced Communication Lab
Changan Auto

CONTENTS

1 ABOUT CHANGAN
长安汽车介绍

2 OUR V2X UNDERSTANDING
长安对V2X的理解

3 V2X R&D PROGRESS
IN CHANGAN
长安V2X研发进展

4 FUTURE PLANNING
未来规划

1.长安汽车介绍

ABOUT CHANGAN

BASIC INFORMATION OF CHANGAN

企业基本信息

Diversified brands: ENVO, DEEPAL, AVATR, UNI, KAICENE, Changan Ford, Changan Mazda, JMC, etc.
涵盖长安启源、深蓝、阿维塔、长安引力、长安凯程等自主品牌，以及长安福特、长安马自达、江铃等合资品牌。

Rich product line-up: Models covering passenger vehicles, pick-ups and light-duty commercials.
产品覆盖乘用车、皮卡和轻型商用车市场。

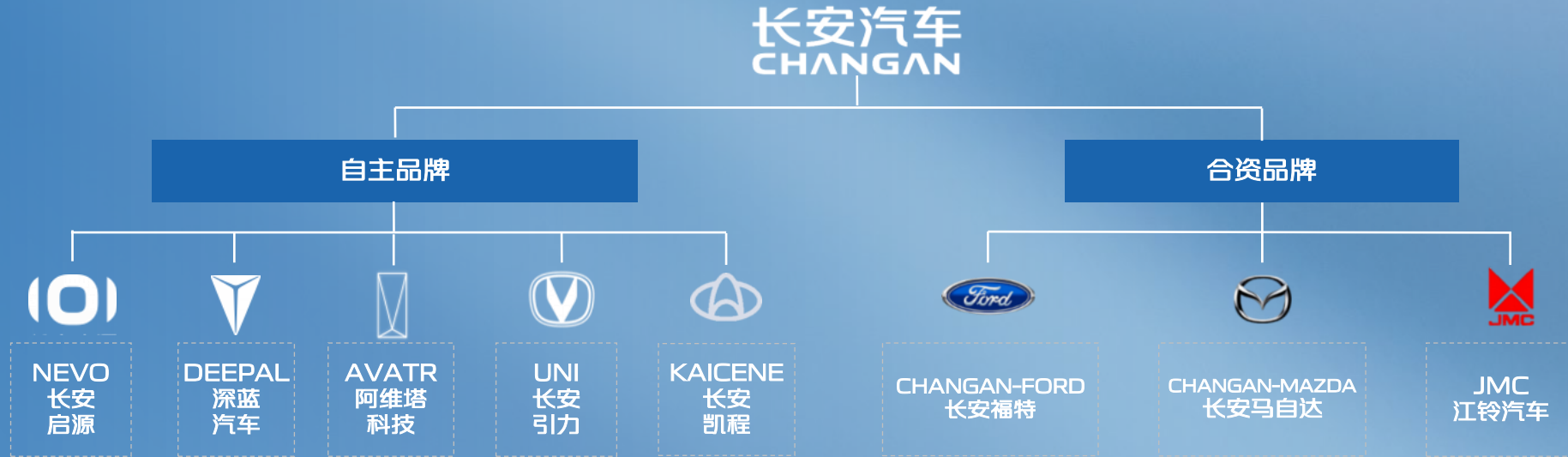

GLOBAL FOOTPRINT

全球产业布局

72,000 employees, creating over 1 million jobs across the industrial chain.

现有员工7.2万人，带动全产业链100余万人就业。

Our market capitalization stands at RMB 210 billion.

公司资产规模2100亿元。

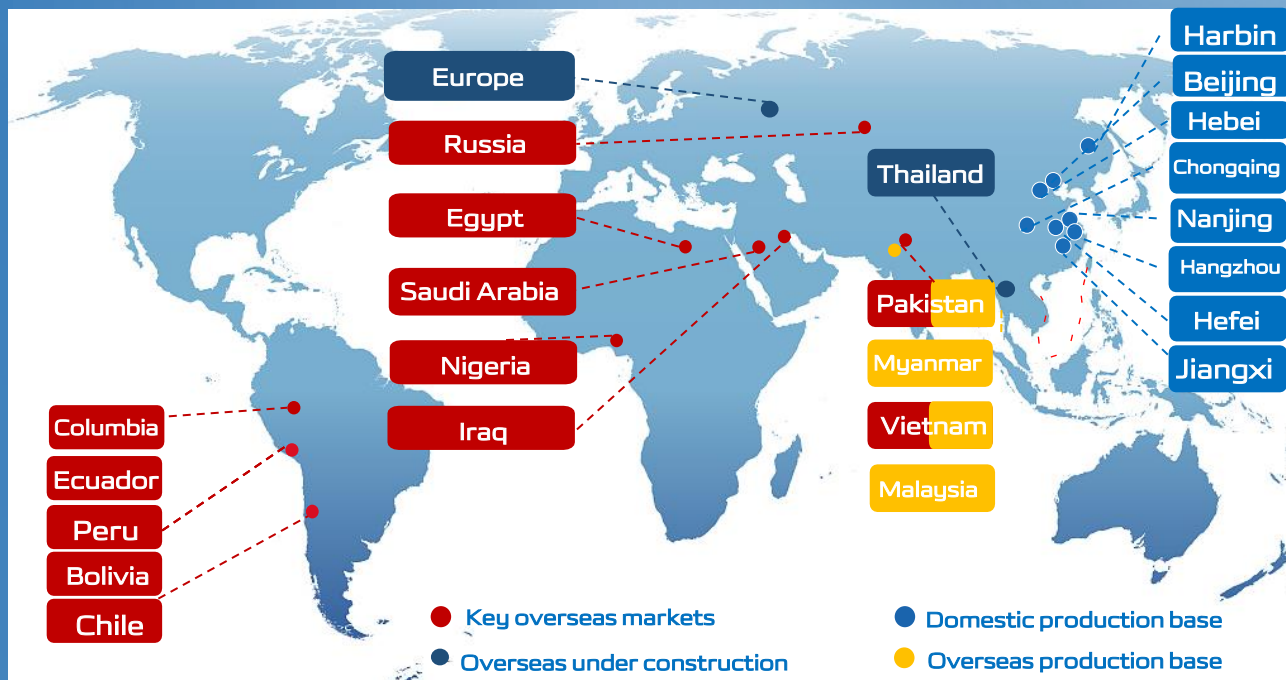

73

branches & subsidiaries
家分子公司

12

manufacturing bases
个全球制造基地

22

Vehicle and new power plants
个整车及新动力工厂

63

countries & regions
个海外销售国家和地区

9000 dealerships / nearly 120,000 service staff

9000余家销售服务网点 / 近12万名专业服务人员

LEADING REPRESENTATIVE OF CHINESE BRANDS

中国品牌的典型代表

Total Sales in 2023

The total sales of Changan in 2023 exceeded

2.55 million units

长安汽车2023年
总销量突破255万辆

Private Brands

The total sales of private brands under Changan exceeded

2.09 million units

长安汽车自主品牌2023年
总销量突破209万辆

New Energy

The total sales of new energy under Changan exceeded

0.48 million units

长安汽车新能源2023年
总销量突破48万辆

Overseas

The overseas total sales of Changan in 2023 exceeded

0.35 million units

长安汽车2023年海外
总销量突破35万辆

GLOBAL R&D LAYOUT

全球研发布局

Around-the-clock: Global R&D network of “six countries and ten centers” .

“六国十地”全球研发布局，24小时协同研发。

16 technology research & product development centers, 17 tech companies.

共有16个技术研究、产品开发中心，17家科技公司。

A R&D team of 18,000 people from 30 countries (over 13,000 R&D staff).

拥有来自全球30个国家，1.8万余人的工程技术团队（研发人员1.3万余人）。

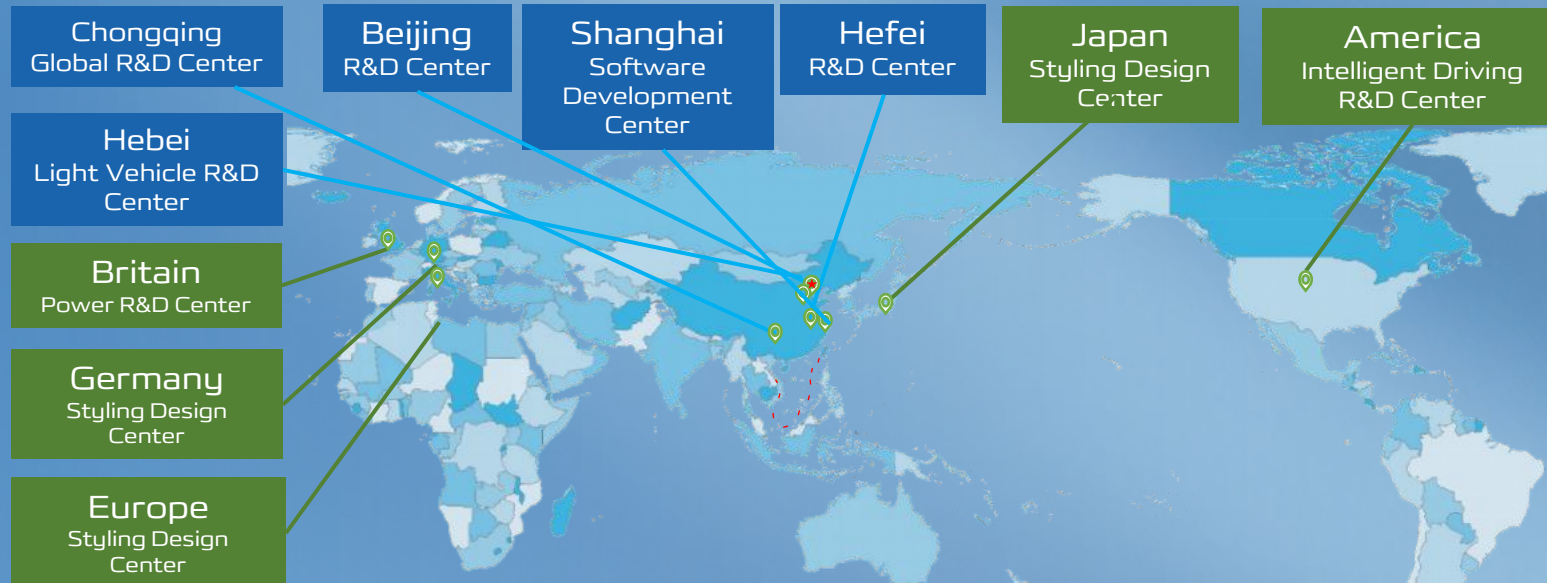

2.长安对V2X的理解

OUR V2X UNDERSTANDING

“DUAL EYES + DUAL BRAIN”

打造“双眼+双脑”的车路云一体化技术

- V2X Technology: Advances in communication and sensing enable vehicles to perceive road conditions in real-time, facilitating information exchange between vehicles, roads, pedestrians, and the cloud.

V2X技术：在单车智能基础上，通过先进的通信、感知、定位设备，对道路环境进行全域实时感知，按照约定的协议进行数据交互，实现车与车、车与路、车与人、车与云之间的信息交互共享。

- Vehicle-Road-Cloud Integrated System: Integrates physical and digital spaces of humans, vehicles, roads, and the cloud using advanced technologies, aiming for a coordinated, safe, energy-efficient, and effective intelligent vehicle transport system.

车路云一体化系统：通过新一代信息与通信技术将人、车、路、云的物理空间、信息空间融合为一体，基于系统协同感知、决策与控制，实现智能网联汽车交通系统安全、节能、舒适及高效运行的信息物理系统。

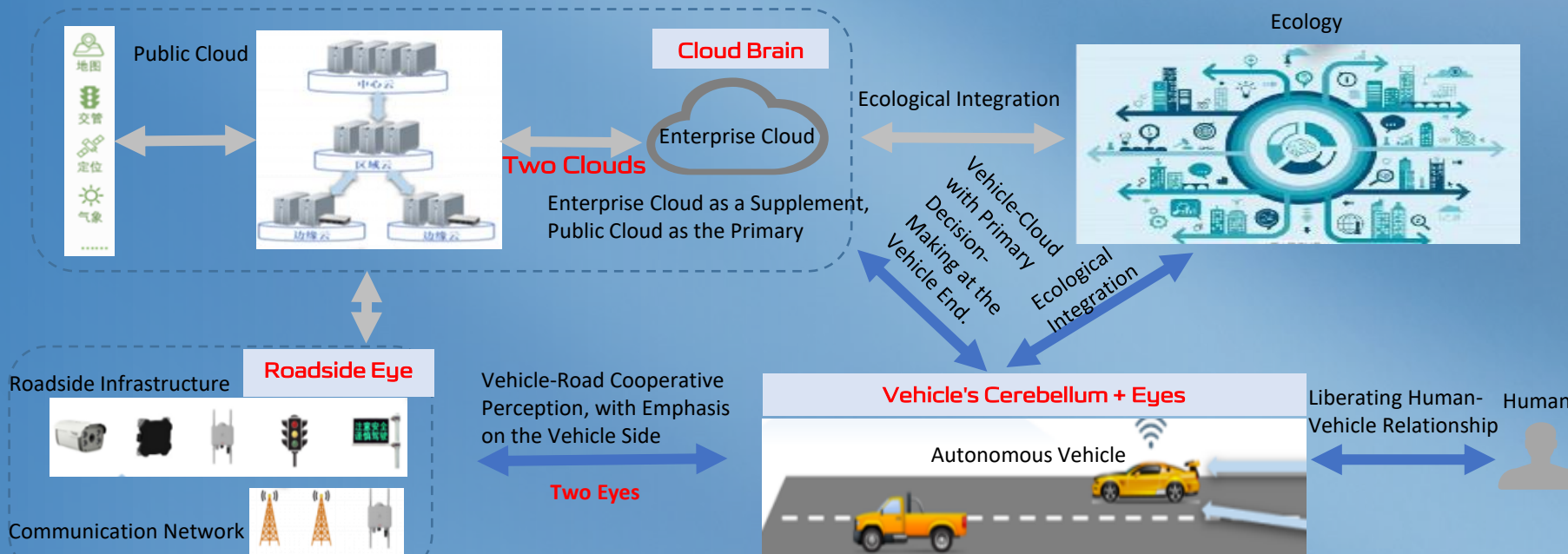

VALUE OF V2X FOR INTELLIGENT CONNECTED VEHICLES

V2X对智能网联汽车的价值

- Empowerment:** V2X technology enhances vehicle perception, enabling comprehensive, real-time interaction between vehicles, roads, people, and the cloud, thus improving safety, efficiency, and user experience.
 赋能：V2X技术可扩展单车感知能力，实现全方位的车-车、车-路、车-人、车-云实时动态信息交互，从安全和效率上提高车辆智能化、网联化水平，提升用户体验。
- Cost Reduction:** The shared cost per vehicle for V2X will tend to decrease as the technology matures and road construction schemes become standardized.
 降本：V2X单车分摊成本会随着技术的成熟及道路建设方案的标准化呈现减少趋势

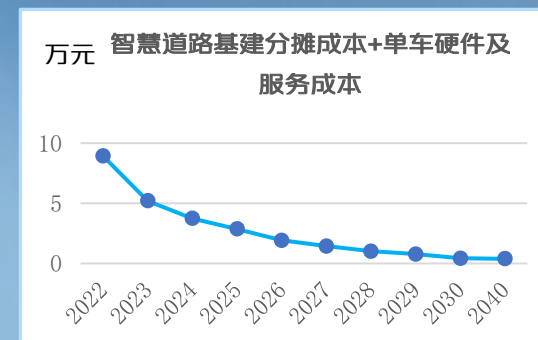
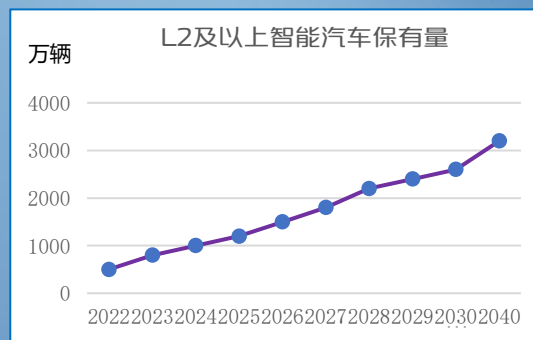
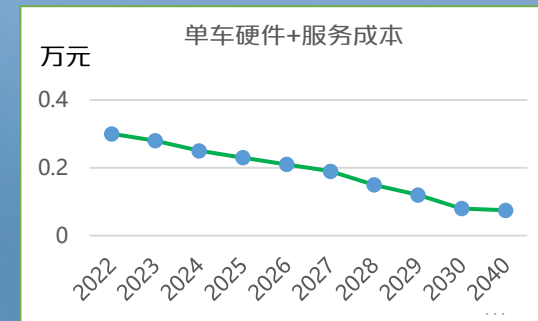
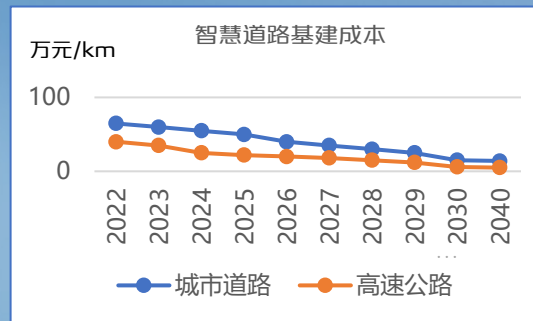
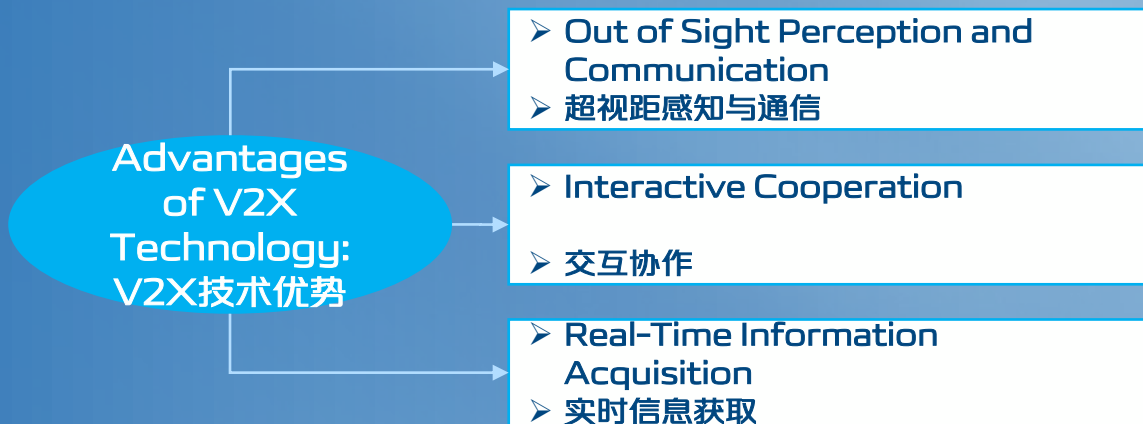

CHALLENGES FOR V2X

V2X面临的挑战

Immature business model
商业模式尚未成熟



Undetermined operational
management entities and models
营运管理主体及模式未定



Weak user need
用户需求不强烈



Scenario mining requires further depth
场景挖掘有待深入



Key technologies await
breakthroughs
关键技术有待突破



Roadside equipment reliability and
functional safety levels remain to be
verified



路侧设备可靠性、功能安全等级尚待验证

3.长安V2X研发进展

V2X R&D PROGRESS IN CHANGAN

R&D HISTORY

研发历程

- Changan started researching V2X in 2012, and has been deeply involved in the development of China's V2X industry in terms of standard setting, application scenario exploration, and test and demonstration operations

长安最早从2012年开始研究V2X，在标准制定、应用场景探索、测试示范运营等多方面深度参与了中国V2X行业发展



STANDARD SETTING

标准制定

- Changan led the development of China's first V2X application layer standard and participated in the development of a number of China's V2X national, industry, and group standards, and has now established a V2X enterprise standard system catalog and released various V2X enterprise standards. 长安牵头制定了中国第一部V2X应用层标准，并参与多项中国V2X国家、行业、团体标准制定，现已建立V2X企业标准体系目录，发布多项V2X企业标准

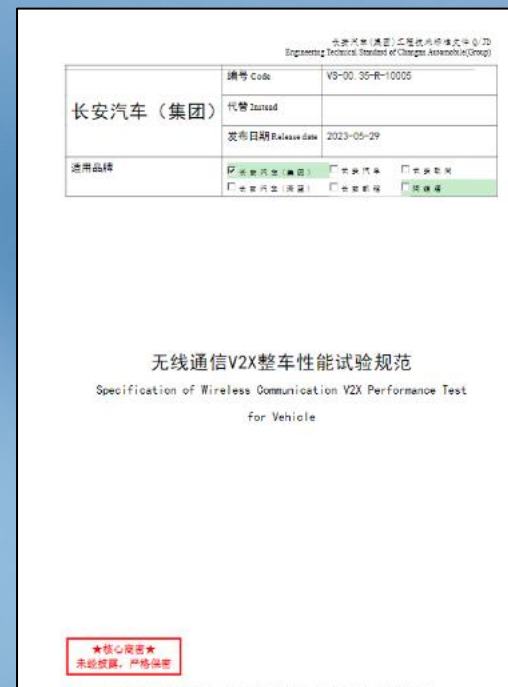
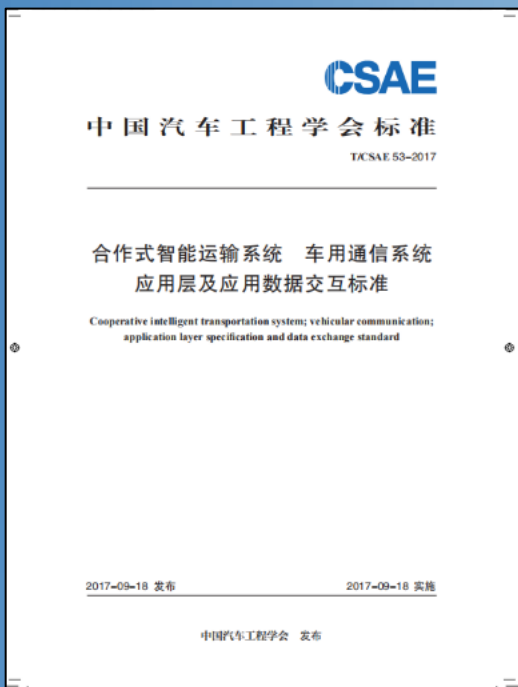

APPLICATION SCENARIO EXPLORATION

应用场景探索

- Multi-dimensional exploration of V2X application scenarios, has developed and verified 20+ V2X function prototypes, dedicated to meet the safety, efficiency, comfort and other requirements of driving and parking scenarios.

多维度探索V2X应用场景，已开发并实车验证20+项V2X功能原型，致力于满足行车和泊车两大用户场景下的安全、效率、舒适等诉求



VEHICLE PROTOCOL STACK DEVELOPMENT

车端协议栈开发

- Completed the design of V2X data servitization at the vehicle end, and realized the design of three major categories and twelve subcategories of atomic services
完成车端V2X数据服务化设计，实现三大类12小类原子服务设计
- Completely self-developed full stack of V2X protocol stack network layer, security layer, I/O layer messaging and service layer, and application layer
完全实现V2X协议栈网络层、安全层、I/O层、消息和服务层、应用层的全栈自研

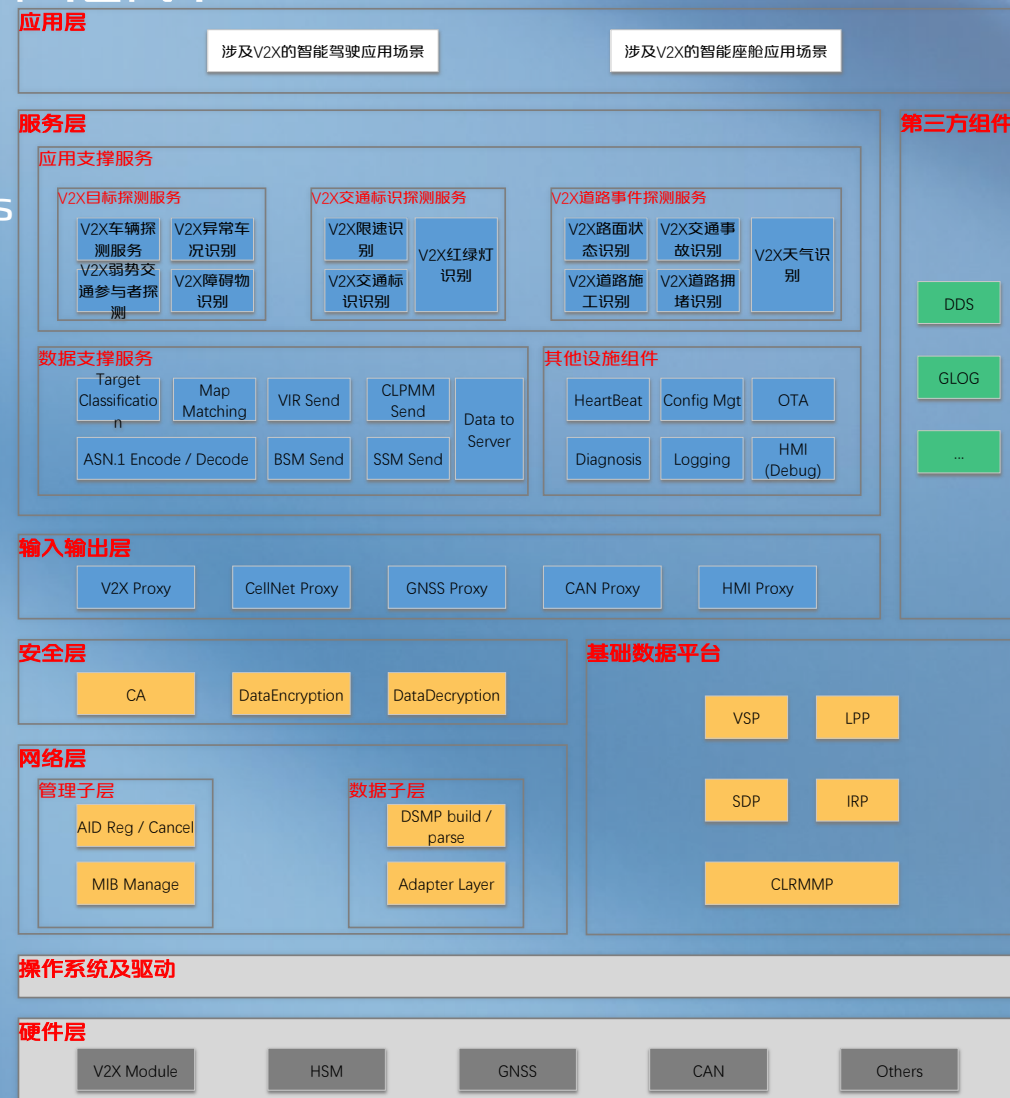
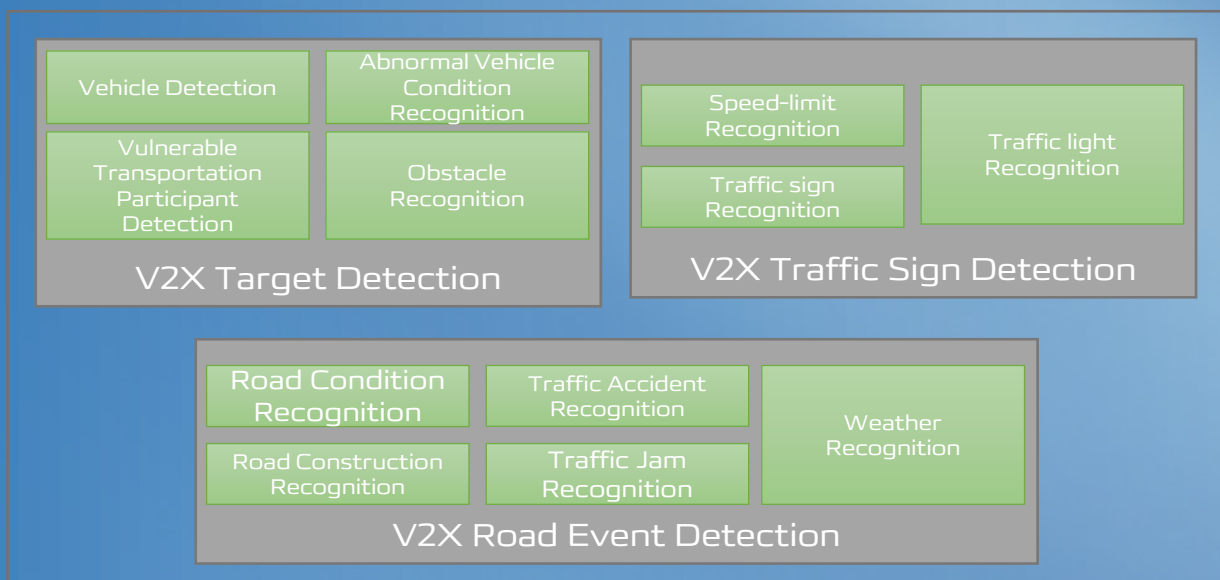

TEST AND EVALUATION CAPACITY-BUILDING

测试评价能力建设

- Professional model vehicle modification team and capability to modify V2X model vehicles of various automation levels based on customized architecture
具备专业的样车改制团队和能力，可基于定制化架构改制各种自动化等级的V2X样车
- A semi-enclosed site for V2X network connectivity testing, with intelligent roadside equipment such as communication, sensing, and computing
具备开展V2X网联化测试的半封闭式场地，场地内具备通信、感知、计算等智能路侧设备
- V2X emulation test bench being built to support V2X HIL and VIL emulation testing
正在搭建V2X仿真测试台架，支持V2X HIL和VIL仿真测试



TEST DEMONSTRATION & DEMONSTRATION OPERATION

测试演示&示范运营

- Participated in domestic and international V2X related test demonstrations and demonstration operations for many years

连续多年积极参与国内外V2X相关测试演示、示范运营实践活动



Invited to conduct a live V2X demonstration



First cross-enterprise V2X interconnect demo



Wuxi World IOT Expo LTE-V2X City-level demonstrations



First to realize demonstration operation for the public



Changan Global R&D Center Campus V2X live vehicle testing

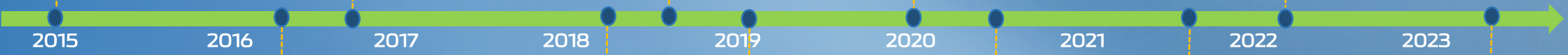

Live Car Demonstrations at the MTC Annual Meeting



First public demonstration of L4 intelligent driving (Fuzhou Digital China Summit)



Continuous participation in China C-V2X "three-span", "four-span" and "new-four-span" test drive program



Validation of C-V2X Functions Based on Map Secrecy Plug-in



MASS PRODUCTION DEPLOYMENT PROGRAM VALIDATION

量产部署方案验证

- Exploring mass production deployment options for V2X functionality in different communication modes (Uu, PC5)

探索不同通信模式 (Uu、PC5) 下V2X功能的量产部署方案

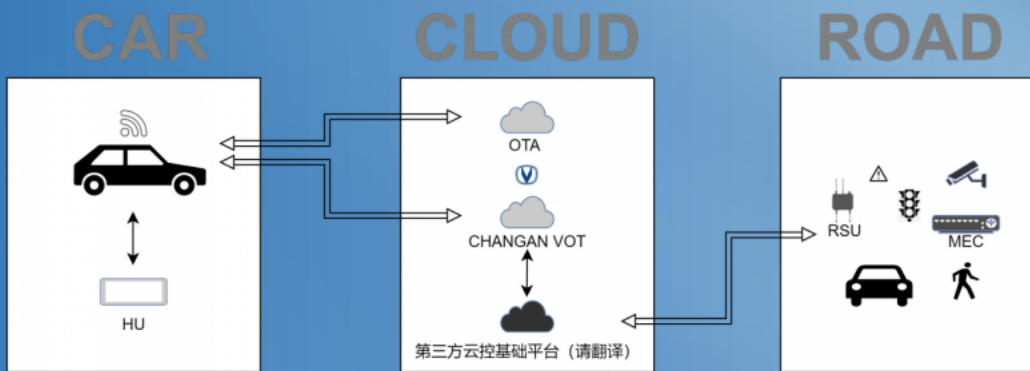

Third-party cloud control infrastructure platform

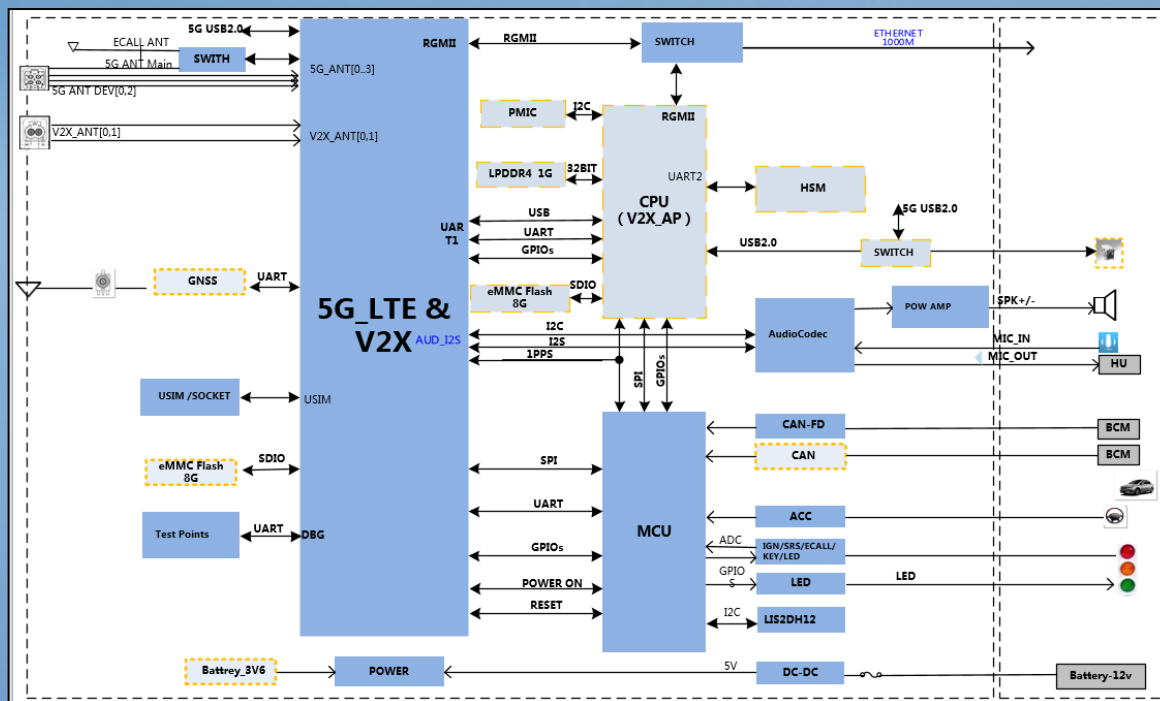
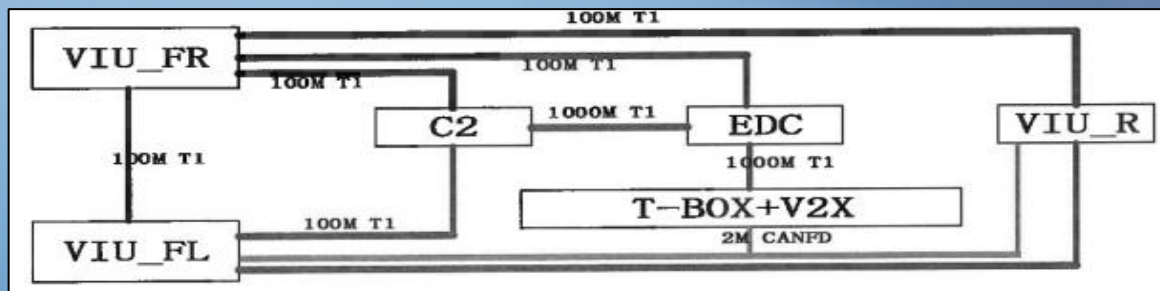

4.未来规划

FUTURE PLANNING

- Recently the V2N solution has been used to promote the upgrade and deployment of V2X warning alerts on production vehicles
近期以V2N方案推进V2X预警提醒功能在量产车上的升级部署
- Conducting prospective research on V2X and intelligent driving fusion, and choosing the right time to advance mass production
同步开展V2X与单车智能融合功能预研，择机推进网联式自动驾驶量产



基于Uu的网联预警提醒功能
Uu-based networking warning alert function



融合V2X的网联式自动驾驶功能
Connected automatic driving with V2X

长安汽车
CHANGAN



Phone:18580176630

Email:lizw@changan.com.cn

Thank you for your attention!



CHANGAN SMART PARTNER OF SCIENCE AND TECHNOLOGY

科技长安 智慧伙伴